

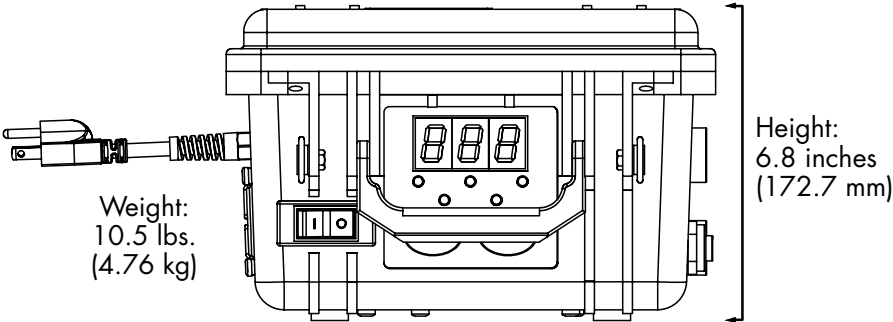

MECHANICAL SPECIFICATIONS

Front View



Weight:
10.5 lbs.
(4.76 kg)

Height:
6.8 inches
(172.7 mm)

Top View

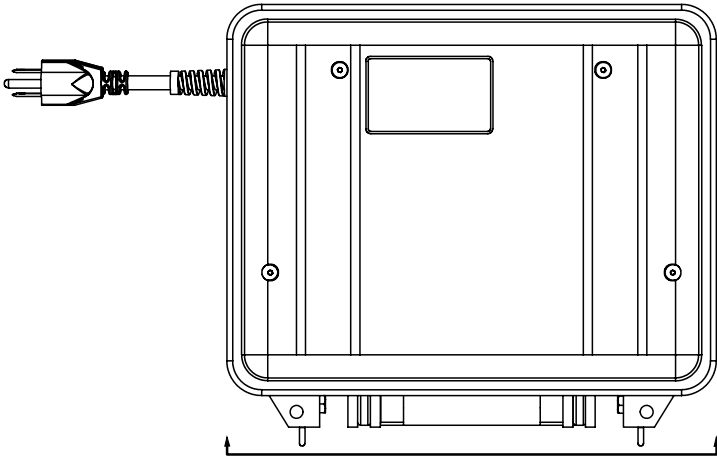

Width: 10.6 inches (269.3 mm)

Side View

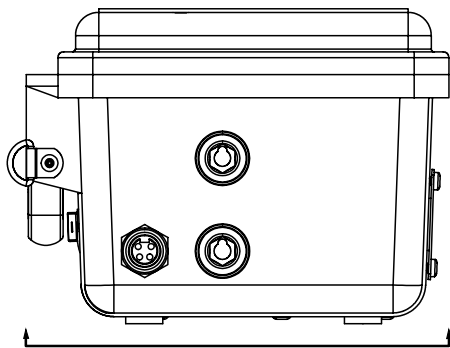

Depth: 9.1 inches (231.1 mm)

ELECTRICAL SPECIFICATIONS

	Incoming	Outgoing
Voltage	115 VAC	40 – 150 VDC
Current	15 Amp	3,000 – 9,000 A
Hertz	60	DC
Capacitance		66,000 µf

CAPACITY SPECIFICATIONS

- Charge Time: <3 seconds to maximum charge
- Duty Cycle: 24 welds/minute at maximum voltage
- Mode – Capacitor Discharge: Contact & Cuphead

OPERATIONAL SPECIFICATIONS

- Indicator Lights (5)
- Resettable Breaker
- Fan Thermal Switch
- Safety Shutdowns
- 7 Segment Voltage/Message Display

WELD GUN

Weight: 1.6 lbs. (.73 kg)
(not including cable)

Size (LWH): 4 7/8" x 2" x 5 3/4"
(123.8mm x 50.8 mm x 146.1 mm)

Weldable Diameter: 14 Ga. thru
1/4" (M6) Dia. Weld Base

Material: High strength, impact
resistant polycarbonate

CABLES

Ground Cable: #4 x 15 ft. (4.6m)
one each

Gun Extension Set: #4 x 18/2 x 35 ft. (10.7m)
direct to gun

*A complete system includes a power supply, weld gun, and ground cable.



Call 1-800-852-8352

450 Richard Street • Miamisburg, Ohio 45342 • Fax: (937) 866-4174 • midwestfasteners.com