

The chart settings shown below are “reference” settings to be used as starting points. Actual voltage settings may vary depending upon the conditions or each application and use.

Pin/Stud Type	Pin/Stud Dia	Pin/Stud Mat'l.	Voltage Setting
Insulation Pin	12 GA	Mild Steel	75-85
	10 GA	or Stainless	85-95
Weld Studs (Flanged)	12 GA	Aluminum	110-120
	10 GA		120-130
	#10 or 3/16"	Mild Steel or Stainless	120-130
	1/4"		145-155
#8	Aluminum	120-130	
#10 or 3/16"		130-140	

VOLTAGE SETTINGS

for ACCESSORIES
and SPARE PARTS
see:

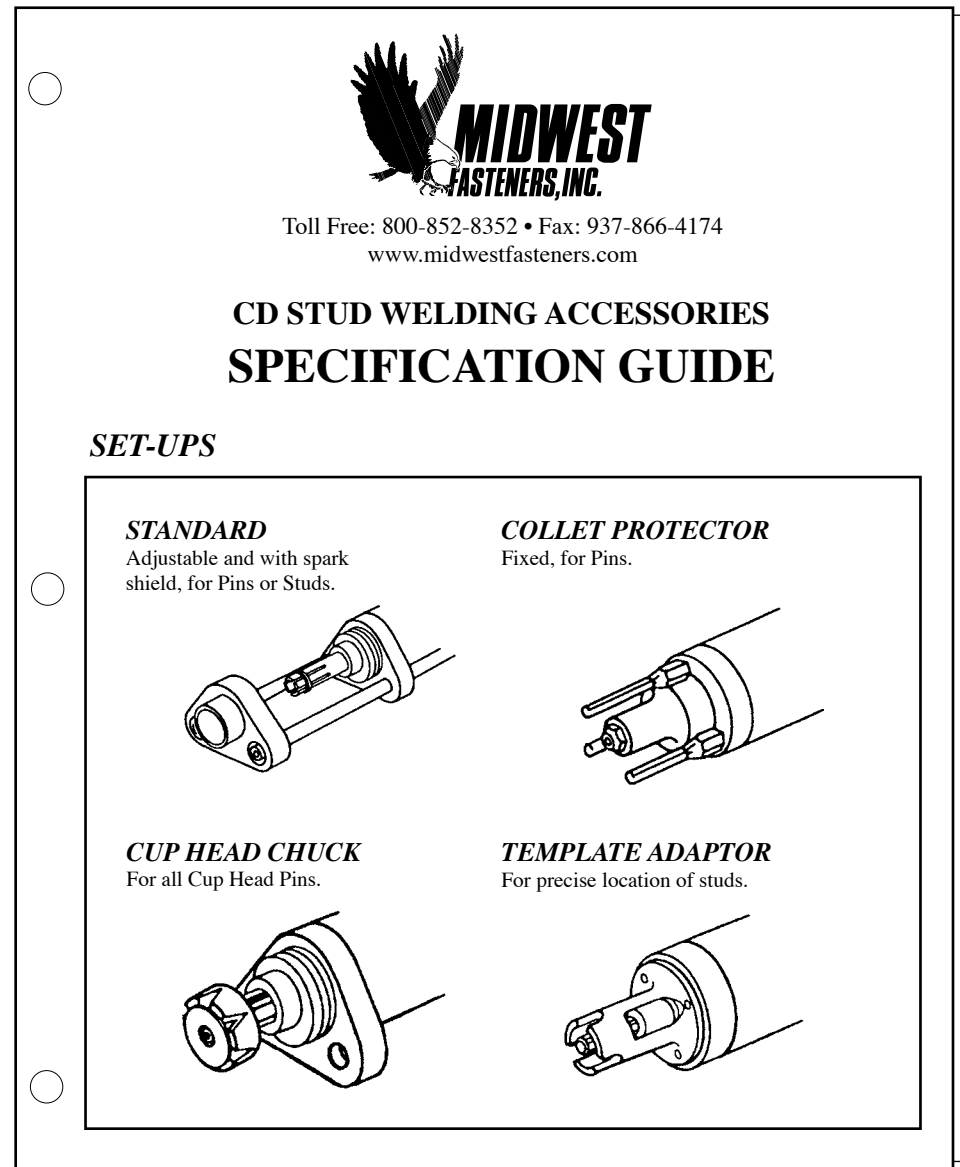

Solid State – Capacitor Discharge
Pin Welding System

Quick Startup Guide





MIDWEST FASTENERS INC.

PARTS

Eagle Components

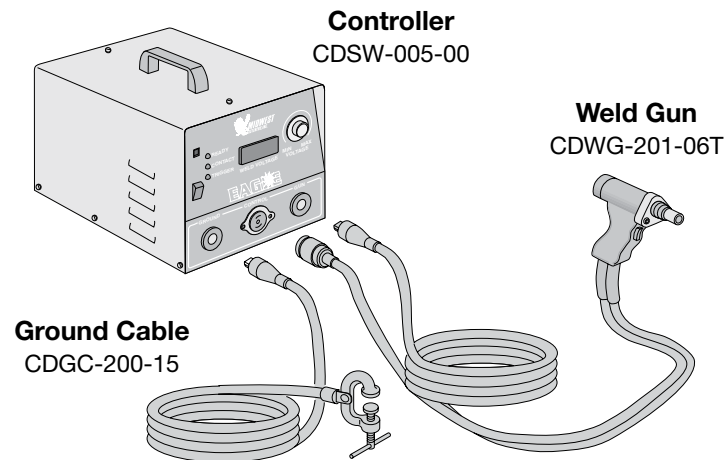

Remove the controller, cables and weld gun from the shipping packaging.

CD-2 WELD GUN SETUP

WELD PINS

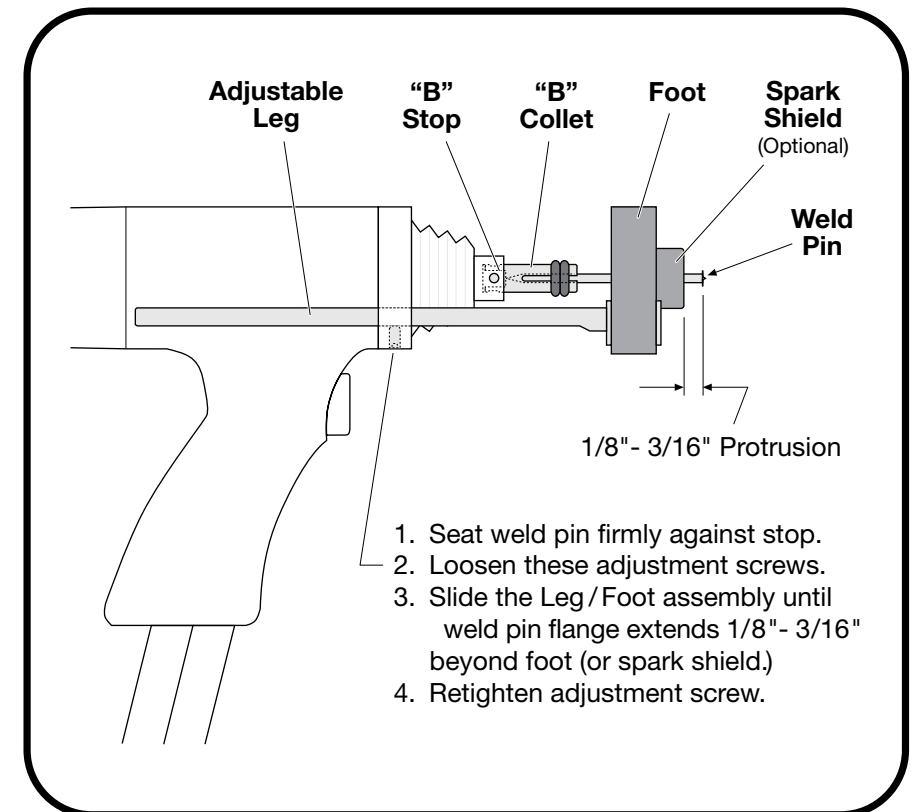

1. Seat weld pin firmly against stop.
2. Loosen these adjustment screws.
3. Slide the Leg/Foot assembly until weld pin flange extends 1/8" - 3/16" beyond foot (or spark shield).
4. Retighten adjustment screw.

Connect the Cable connectors to the controller as marked: "GROUND" or "GUN".

SETUP

Eagle Cable Connections

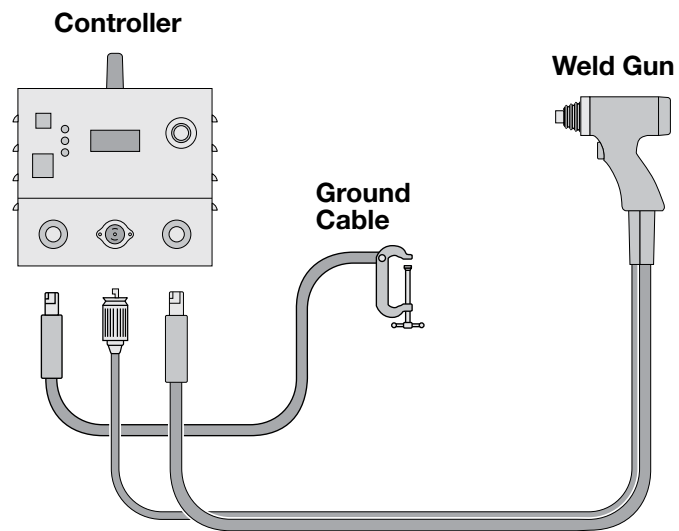

NOTE: All cables should be laid out straight or in a random fashion.

CD-2 WELD GUN SETUP

INSULATION PINS WITH COLLET PROTECTOR

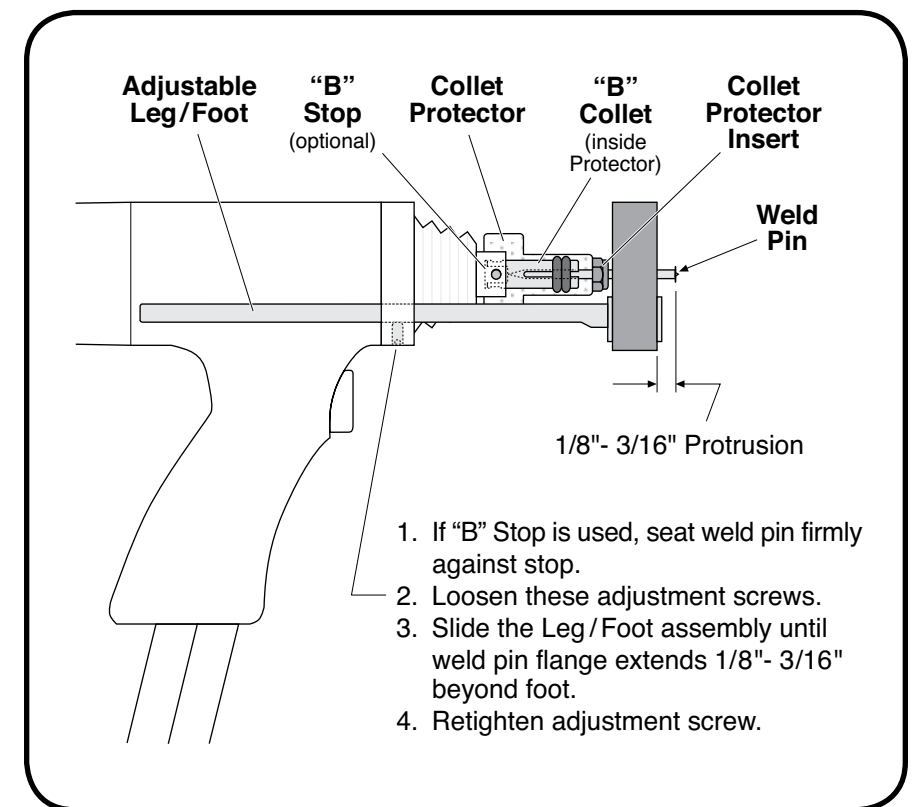

1. If "B" Stop is used, seat weld pin firmly against stop.
2. Loosen these adjustment screws.
3. Slide the Leg/Foot assembly until weld pin flange extends 1/8" - 3/16" beyond foot.
4. Retighten adjustment screw.